

# HR150U Receiver

## User Guide



www.spectraprecision.com

### Introduction

Thank you for choosing the Spectra Precision® Laser Receiver HR150U from the family of precision instruments. The HR150U is a battery-operated laser receiver that detects a rotating laser beam and indicates its position relative to the beam using LEDs.

Before using the receiver, be sure to read this user guide carefully. Included in it is information about setting up, using, and maintaining the receiver. Also included in this manual are **CAUTIONS** and **Notes**. Each of these words represents a level of danger or concern. A **CAUTION** indicates a hazard or unsafe practice that could result in minor injury or property damage. A **Note** indicates important information unrelated to safety.

Your comments and suggestions are welcome; please contact us at:

Spectra Precision (USA) LLC  
3265 Logistics Lane, Suite 200  
Dayton, OH 45377 USA  
888-527-3771 (Toll Free)

www.spectraprecision.com

### Receiver

#### Features and Functions

- Power/Audio Button**—is a multi-functional button that turns on/off the receiver and audio function.
- Marking Notches (both sides)**—align with the on-grade portion of the photocell and are used to mark elevation readings. The marking notches are 50mm (2 inches) from the top of the receiver.
- LEDs (front and back)**—show the position of the receiver relative to the laser beam (high, on-grade, or low), and indicate power and low-battery status.
- Level Bubble**—is used to make sure that the receiver is level.
- Photocell**—detects the laser beam when it strikes the receiver.
- Audio Port**—is the opening the sound comes out of.

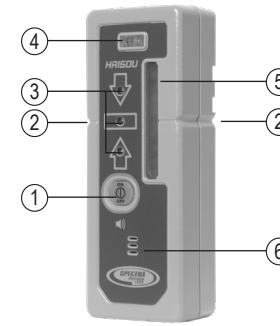

- Clamp-Tab Recess**—is the area that the general-purpose clamp's release tab fits into.
- Label**—shows the serial number and bar code.
- Magnet**—holds the receiver on a wall molding, cross-T, runner, etc.
- Battery Housing**—holds two AA alkaline or Ni-Cd batteries.
- Battery Door**—holds the batteries securely in place.
- Neck Cord Holder**—allows a neck cord to be attached to the receiver.

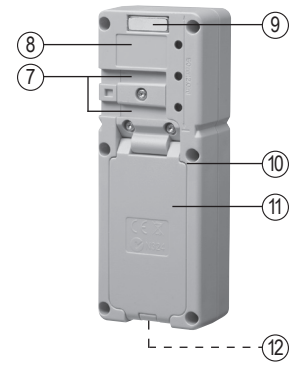

### How to Use the Receiver

#### Installing/Removing the Batteries



- Release the battery door using your fingers, a coin, or a screwdriver. Open the door.
- Install/Remove the 2 AA batteries noting the positive (+) and negative (-) diagram on the bottom of the battery housing.
- Close the battery door and latch it shut.

#### Learning the Receiver Functions

##### Turning On/Off the Receiver

- Press the power/audio button to turn on the receiver.

**Note:** When the receiver is initially turned on, all LEDs and the audio signal turn on for one second (diagnostic mode).

**Note:** The on-grade LED flashes once every two seconds to show that the receiver is on.

- Press and hold the power/audio button for two seconds to turn off the receiver.

**Note:** When the receiver is being turned off, all the LEDs and the audio signal quickly turn on for one second.

##### Selecting the Audio Function

The receiver always starts up with the audio mode active.

- Press the power/audio button repeatedly to turn on/off the audio function.

**Note:** If the audio function is on, the receiver beeps quickly when the receiver is above the laser beam, slowly when below it, and continuously when centered in the laser beam or on grade.

#### Using the Receiver with a Laser

- Press the power/audio button to turn on the receiver.
  - Position the receiver so that its photocell faces the laser.
  - Move the receiver up/down until the LEDs show an on-grade reading.
- Note:** The top/bottom red LEDs flash when the receiver is above or below the laser beam. The green LED flashes when the receiver is on grade.

#### LED/Audio Information

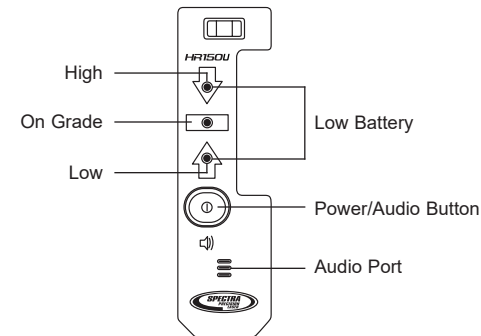

LED/Audio Indication	Function	Audio Output
Green LED: flashes once every two seconds	Receiver is on	N/A
Top red LED: flashing	High	Fast beeping tone
Green LED: flashing	On-grade	Continuous tone
Bottom red LED: flashing	Low	Slow beeping tone
Both red LEDs: flashing in sequence	Low battery	N/A
Speaker beep	Audio on	3 beeps
	Beam location	Single beep

## General-Purpose Clamp

The C61 general-purpose clamp allows the receiver to be attached to a survey rod or wooden pole.

### Features and Functions

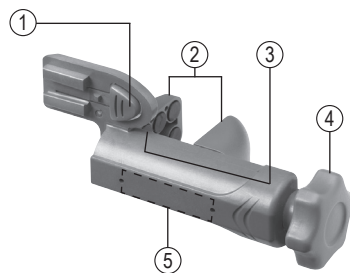

1. **Release Tab**—allows the receiver to be locked onto or released from the general-purpose clamp.
2. **Jaws**—close/open so that the general-purpose clamp can be attached to or released from a survey rod or wooden pole.
3. **Reading Edge**—aligns with the receiver's on-grade marking notches.
4. **Jaws Screw**—controls the closing/opening of the jaws.
5. **Circular Bubble Screw Holes**—are where the optional 1277-6251S grade rod circular bubble kit is mounted.

– 9 –

## EMC Declaration of Conformity

This receiver has been tested and found to comply with the limits for a Class B digital device for radio noise for digital apparatus set out in the Radio Interference Regulations of the Canadian Department of Communication, and is pursuant to part 15 of the Federal Communication Commission (FCC) rules. These limits are designed to provide reasonable protection against harmful interference in a residential installation. This receiver generates radio frequency. If it's not used in accordance with the instructions, it may cause harmful interference to radio or television reception. Such interference can be determined by turning the receiver off and on. You are encouraged to try eliminating the interference by one or more of the following measures:

- Reorient or relocate the receiving antenna.
- Increase the separation between the laser and the receiver.

For more information, consult your dealer or an experience radio/television technician.

**CAUTION:** Changes or modifications to the receiver that are not expressly approved by Spectra Precision could void authority to use the equipment.

– 13 –

## Attaching the Receiver to the Survey Rod or Wooden Pole

1. Slide the general purpose clamp into the receiver until it "clicks" into position.
2. Turn the jaws screw counterclockwise to open the clamp's jaws.
3. Slide the survey rod or wooden pole between the clamp's jaws.
4. Turn the jaws screw clockwise to hold the general-purpose clamp securely in place.



– 10 –

## Declaration of Conformity

Application of Council Directive(s): 89/336/EEC  
 Manufacturer's Name: Spectra Precision (USA) LLC  
 Manufacturer's Address: 3333 Warrenville Rd. Unit 200 Lisle, IL 60532 U.S.A.  
 European Representative Address: Spectra Precision (Kaiserslautern) GmbH Am Sportplatz 5 67661 Kaiserslautern, Germany HR150U  
 Model Number: EC Directive 89/336/EEC using EN55022 and EN50082-1  
 Conformance to Directive(s): ITE/residential, commercial & light industrial  
 Equipment Type/Environment: Product meets the limit B and methods of EN55022  
 Product Standards: Product meets the levels and methods of IEC 801-2, 8 kV air, 4 kV contact IEC 801-3, 3 V/m 26 to 1000 MHz 80%, @ 1 kHz

– 14 –

## Receiver Specifications

LED Channels	3
Capture Height	50 mm (2 in.)
Acceptance Angle	90°
On-Grade Sensitivity	Medium: 3.00 mm (1/8 in.)
Power Source	Two 1.5-V batteries (type LR6/AA)
Battery Life @ 20 °C (68 °F)	Alkaline: 70+ hours
Low Battery Indicator	Red LEDs flash in sequence
Automatic Shutoff	30 minutes after last laser detection or push-button actuation
Spectral Sensitivity	Operates with red visible and infrared rotating lasers with wavelength between 610 and 900 nm
Marking Notch	50 mm (2 in.) below top of receiver, on both sides
Operating Temperature	–20 °C to +50 °C (–4 °F to +122 °F)
Storage Temperature	–40 °C to +70 °C (–40 °F to +158 °F)
Weight	0.3 kg (.75 lb)
Dimensions (H x W x D)	13.6 x 5.0 x 2.8 cm (5.37 x 2.00 x 1.11 in.)

– 11 –

## Warranty

Spectra Precision LLC warrants the receiver to be free of defects in material and workmanship for a period of three years.

Spectra Precision LLC or its authorized service center will repair or replace, at its option, any defective part for which notice has been given during the warranty period. If required, travel and per diem expenses to and from the place where repairs are made will be charged to the customer at the prevailing rates.

Customers should send the product to the nearest authorized service center for warranty repairs, freight prepaid. In countries with Spectra Precision LLC subsidiary service centers, the repaired product will be returned to the customer, freight prepaid.

Any evidence of negligent, abnormal use, accident, or any attempt to repair the product by other than factory-authorized personnel using Spectra Precision LLC certified or recommended parts, automatically voids the warranty.

The foregoing states the entire liability of Spectra Precision LLC regarding the purchase and use of its equipment. Spectra Precision LLC will not be held responsible for any consequential loss or damage of any kind.

This warranty is in lieu of all other warranties, except as set forth above, including any implied warranty merchantability of fitness for a particular purpose, are hereby disclaimed. This warranty is in lieu of all other warranties, expressed or implied.

– 15 –

## Protecting the Environment

The unit, accessories and packaging ought to be recycled.

All plastic parts are marked for recycling according to material type.



Do not throw used batteries into the garbage, water or fire. Remove them in compliance with environmental requirements.



Precision Laser & Instrument, Inc.  
 85 11th Street  
 Ambridge, PA 15003  
 (724) 266-1600



Spectra Precision (USA) LLC  
 3265 Logistics Lane, Suite 200  
 Dayton, OH 45377 USA  
 888-527-3771 (Toll Free)

www.spectraprecision.com

Spectra Precision  
 (Kaiserslautern) GmbH  
 Am Sportplatz 5  
 67661 Kaiserslautern  
 Germany

+49-6142-2100-0 Phone

