



# TRIMBLE MX50

## MOBILE MAPPING SYSTEM

### USER GUIDE

Revision C  
November 2021

## Legal information

### Contact

Trimble Inc.  
10368 Westmoor Drive  
Westminster CO 80021  
USA

[geospatial.trimble.com](http://geospatial.trimble.com)

### Copyright and trademarks

© 2021, Trimble Inc. All rights reserved.

Trimble, the Globe & Triangle logo, and Autolock are trademarks of Trimble Inc., registered in the United States Patent and Trademark Office and other countries. All other trademarks are the property of their respective owners.

### Release Note

This is the November 2021 release, Revision C of the *Trimble MX50 User Guide*, P/N T001774. It applies to:

- Trimble MX50 and all of its variants.

The T001774 original document is written in English. All documents in other languages are translations from the original English document.

### Registration

To register your product or check the status of your system maintenance, please register your system and software at <https://mytrimbleprotected.com/>.

*My Trimble Protected* enables Trimble users, channel partners, and end customers to streamline business processes for customer engagement and service. As a centralized instrument panel, *My Trimble Protected* manages registrations, serial number lookups, product catalogs, reports, settings, and locator processes. It allows users to configure, monitor, and optimize each aspect of the process.

## Compliance Information

### Europe

#### EC Compliance

Trimble declares that the MX50 and associated accessories comply with the applicable directives, standards, and regulations.



WARNING: Trimble MX50 Equipment is Class A.

This is a class A product. In a domestic environment this product may cause radio interference in which case the user may be required to take adequate measures.

#### WEEE

Notice to our European Customers

For product recycling instructions and more information, please go to:

[http://www.trimble.com/Corporate/Environmental\\_Compliance.aspx](http://www.trimble.com/Corporate/Environmental_Compliance.aspx)



Recycling in Europe: To recycle Trimble® batteries and WEEE (Waste Electrical and Electronic Equipment, products that run on electrical power),

Call +31 497 53 24 21 or mail a request for recycling instructions to:

Trimble Europe B.V. & Trimble International B.V.  
Industrieweg 187a  
5683 CC Best  
The Netherlands

## United Kingdom

### UK Compliance

Trimble declares that the Trimble MX50 system and associated accessories comply with the applicable directives, standards, and regulations.

WARNING: Trimble MX50 Equipment is Class A.

This is a class A product. In a domestic environment this product may cause radio interference in which case the user may be required to take adequate measures.



## USA

### FCC Statement

This device complies with part 15 of the FCC rules. Operation is subject to the following two conditions:



- (1) This device may not cause harmful interference.
- (2) This device must accept any interference received, including interference that may cause undesired operation.

NOTE: Trimble MX50 Equipment is Class A.

In order to maintain compliance with FCC regulations shielded cables must be used with this equipment. Operation with non-approved equipment or unshielded cables is likely to result in interference to radio & television reception.

## CANADA

### ICES Statement

NOTE: Trimble MX50 Equipment is Class A.

This Class A digital apparatus complies with Canadian ICES-003.

Cet appareil numérique de la classe A est conforme à la norme NMB-003 du Canada.

## Australia / New Zealand

### ACMA Statement

WARNING: This is a Class A product. In a domestic environment this product may cause radio interference in which case the user may be required to take adequate measures.



# Contents

Legal information .....	2
Compliance Information .....	2
<b>1 Safety Instructions .....</b>	<b>7</b>
Acclimatisation .....	7
General .....	7
Electronics .....	8
Laser .....	8
Mechanics .....	9
Usage, Installation and Transportation .....	10
<b>2 System Overview and Installation .....</b>	<b>12</b>
Introduction .....	12
Sensor Unit .....	13
Description .....	13
Dimensions .....	14
Installing the Sensor Unit .....	14
Uninstalling the Sensor Unit .....	17
Control Unit .....	18
Description .....	18
Dimensions .....	21
Installation .....	22
Power Unit .....	23
Description .....	23
Dimensions .....	24
Properties and Functionality .....	26
Installation .....	27
Roof Rack .....	28
Description .....	28
Basic Requirement for a Car Roof .....	28
Basic Requirements for Universal Roof Bars .....	29
External Reference Point .....	29
Dimensions .....	30

- Installation Restrictions ..... 31
- Adjusting the Position of the MX SCAN Roof Rack on the Roof Bars ..... 31
- Cables - Identification & Installation .....33
- User Interface Device .....35
  - Connecting the Device via the Ethernet .....35
  - Connecting the Device via Wi-Fi .....36
- Storage and Transportation .....37
  - Delivered Items ..... 37
  - Use Assumptions .....40
  - Storage .....40
- Optional Accessories ..... 41
  - DMI .....41
  - GAMS .....42
- 3 Operation ..... 43**
  - Safety Check ..... 43
    - Components Checklist ..... 43
  - External Reference Point .....44
    - Measuring Installation Parameters and Lever Arms .....44
    - Configuring the MX50 system for Operation .....46
  - Prerequisites to System Setup and Operation .....47
  - System Software .....47
- 4 Maintenance and Support .....48**
  - Maintenance .....48
    - Preventive Maintenance .....48
    - Lubrication of Movable Parts .....49
    - Cleaning the Camera Lens Glass and Laser Glass .....49
  - Support .....50
    - General .....50
    - Trimble Land Mobile Download Center .....50
- 5 Appendix .....51**
  - Technical Specifications .....51
    - MX50 System .....51
    - Spherical Camera Performance .....53

Contents

- Laser Performance ..... 53
- Scanner and Laser Specifications ..... 54
- POS System Performance ..... 55
- Abbreviations ..... 57
- Vehicle Requirements ..... 58
  - General ..... 58
  - Mechanical ..... 58
  - Electrical ..... 58
  - Typical Installation Example ..... 59
- Installing a Power Supply in a Vehicle for Safely Operating the MX50 System ..... 60
  - Typical Power Supply Setups ..... 61
- External-Signal Connector ..... 62
  - Detailed Signal Description ..... 63
- Setting the Location of the GAMS Antenna ..... 66

# Safety Instructions





## Acclimatisation

The Trimble MX50 system incorporates sensitive electronics and optical components.

Due to variation in temperature and air pressure during airfreight transportation, rapid increase of temperature after unpacking may cause condensation of water inside the main components of the Trimble MX50 system (Sensor Unit, Control Unit, Power Unit). Water inside the components respective their housings can cause short circuits and can damage the instrument when switched on.





Therefore, after air freight transportation, allow a period of 24 hours for acclimatisation in a place with constant temperature and air pressure before switching on the Trimble MX50 system.

## General

	<p>The Trimble MX50 system was developed for acquisition of 360° images and laser point cloud data in mobile mapping applications.</p> <p>This system is designed for industrial usage only. Any other usage can be dangerous and is strictly forbidden. The system must be used only by well-trained persons.</p>
	<p>Any unauthorized changes to the product, including software changes made through whatever means, can cause personal injury or damage to the system and renders all guarantees null and void.</p>
	<p>Any final installation of the Trimble MX50 system or its components is under control and responsibility of the owner, or the person authorized by the owner.</p>
	<p>It is the customer's responsibility to ensure that there are adequate mounting facilities and the component layout has been planned carefully. If necessary, the customer must obtain the approval of the local authorities before installing the Trimble MX50 system or any of its components.</p>
	<p>We strongly recommend that you check the quality of the acquired data on a regular basis. Especially before starting an extensive data acquisition campaign.</p>



	This check can for example be carried out by registering a scan position by means of scanning a number (e.g. 8) of flat retro-reflecting targets at different distances and at angles covering a range of more than 180° horizontally, which have also been surveyed by a highly accurate total station. The check is passed if the residual error is less than the instrument's specified accuracy.
--	--

## Electronics



	The system must never be connected to 110, 230, or 400 VAC! Opening the instrument is unacceptable and must therefore be avoided at all costs.
	Electrostatics can destroy the system.
	Before and after every mission, check all system cables, connectors and pins for damage or notches. Do not use damaged system cables!
	To prevent electric shock and damage, do not plug in, connect or handle with wet hands.
	In vehicles using electric propulsion, make sure you install the product in such a way that it is fully separate from the car battery charging system.

## Laser







The installed laser instruments are classified as Class 1 laser products in compliance with the International Standard IEC60825-1:2014 and the European Standard EN60825-1:2014 "Safety of Laser Products- Part 1: Equipment Classification and Requirements".

	Never open the instruments housing!
	Do not operate evidently damaged instruments!
	Do not look unnecessarily into the transmitter aperture!













	<p>Do not point the transmitter aperture unnecessarily at people's eyes.</p>
	<p>Do not align the laser scanners of the Sensor Unit with infrared cameras or night vision devices as this may damage these devices!</p>
	<p>Do not expose the instrument or its components (including electrical cables and accessories) to radioactive radiation. This can completely degrade or even destroy the highly sensitive electronics and electro-optical components. Furthermore, it is practically impossible to decontaminate the equipment after exposure to radioactive radiation.</p>

## Mechanics

	<p>All mechanical parts must be checked before and after each mission (e.g. screws, damage on mechanical parts, etc.).</p>
	<p>During non-operating or storage time intervals, the Sensor Unit should be protected from the environmental conditions (it should be stored in its storage case).</p>
	<p>Do not open the devices!</p>
	<p>Never modify any of the devices!</p>
	<p>Never push objects of any kind into sockets or connectors.</p>
	<p>If there is a need for changing standard parts in the Trimble MX50 system (screws, washers, etc.), always use the same type of material.</p>

## Usage, Installation and Transportation

	When not collecting data or preparing the system for future campaigns, store the Sensor Unit safely in its storage case, taking care to cover the laser scanner units.
	When the Trimble MX50 system is not in use for a longer period of time, turn it on at regular intervals of time (every two months) and keep it running for 30 to 60 minutes to avoid that internal CMOS batteries get too low.
	Make sure the people who are involved in installing or uninstalling the MX50 system and its components are familiar with the “installation” chapter of this manual and have received prior training before handling the system.
	All connections/screws must be tightened by complying with the torque values recommended in the manual!
	Owing to its weight and particular handling required, the MX SCAN Roof Rack and Trimble MX50 Sensor Unit should be installed by two operators.
	Lift or carry the Sensor Unit with the dedicated handles!
	During operation, all components of the MX50 system must be safely and firmly secured to avoid any unwanted move. Cables should be fixed and secured with straps or binders. All other components should be mounted or strapped using the dedicated facilities!
	The MX50 is designed to be used only on board vehicles fitted with rubber wheels and driven on paved surfaces.
	The maximum speed of a vehicle fitted with the MX50 system should not exceed 110 km/h (68 mph).
	The driver should remember that the MX50 system brings additional height to the vehicle and so should be aware of the total height of the vehicle!
	The driver is not allowed to operate the system while driving. It is recommended that a second person be dedicated to operating the system.

	Never operate the system in any other way than explained in the manual!
	Avoid to work overhead. Use tools to get a better position for installation.
	Switch off the vehicle engine during MX50 system installation.
	Clean all optics of the sensors before starting a mission. Depending on weather and road surface conditions, a cleaning of the optics during the mission might be necessary to collect good quality data.
	In order to avoid the danger of suffocation, keep plastic foils, bags and bubble wraps away from babies and children. Do not use them in or near children's bed, pushchairs or playpens. Packaging materials are not a toy, so please tie them up before disposing of them.
	Keep product surfaces clean and dry, always unplug the instrument before cleaning.
	Do not place any liquids on or next to the instrument or its components.
	For data backup, the exchangeable data disc must be taken out of the Control Unit before connecting a USB cable. Never connect the USB cable when the exchangeable data disc is inside the Control Unit.

# System Overview and Installation

## Introduction

The Trimble® MX50 mobile mapping system is a practical system that combines precise Trimble Lidar technology and immersive panoramic imagery. The MX50 system is an accurate and high-productive solution for mapping and asset management applications as well as for road maintenance projects. The system is fully integrated into Trimble Mobile Mapping workflow, which provides customers with an efficient workflow from field to deliverable supported by a single dependable solution supplier. Using the complete Trimble solution, MX50 system users can collect and process rich geospatial data, perform feature extraction and asset maintenance, publish deliverables via the web and integrate with established reference software systems.

Highly accurate and geo-referenced high-density point cloud data can be collected even at regular vehicle speeds on roads.

High-precision and high-density point cloud data can be used not only for GIS asset extraction, but also to perform 3D measurements of highway characteristics such as 3D model generation, road surface measurements, road clearance measurements.

The Trimble MX50 system consists of three main devices:

- Trimble MX50 Sensor Unit (SU)
- Trimble MX SCAN Control Unit (CU)
- Trimble MX SCAN Power Unit (PU).

An additional and specially designed MX SCAN Roof Rack (RR) is used to mount the Trimble MX50 Sensor Unit on top of a vehicle. It can easily be detached for safe indoor storage at the end of the day.

The Trimble MX50 Sensor Unit includes the laser scanners, a 360° camera and the GNSS/IMU system.

The Trimble MX SCAN Control Unit is used both as a computer for controlling the Trimble MX50 Sensor Unit and a recording device for sensor data (Navigation, LiDAR, Camera). The recording device consists of a large-capacity SSD.

The Trimble MX SCAN Power Unit, which is the electrical interface to the power source, provides the equipment with power.

A tablet or PC (BYOD) can be used to operate the system. Connection to the Control Unit is achieved through wired Ethernet or Wi-Fi. The system operation and data collection is controlled through a web browser (no additional software needed).



## Sensor Unit

### Description

The MX50 Sensor Unit is fully equipped with two laser scanners, a 360-degree panoramic camera and a position-and-orientation system, utilizing an integrated inertial technology device for precise vehicle trajectory determination.

The Sensor Unit is additionally equipped with one main connector (on the left side of the Sensor Unit) and three additional connectors (on the right side of the Sensor Unit):

- **Main Connector:** Used to connect the Control Unit to the Sensor Unit
- **Ant.:** Used to connect the Trimble GAMS antenna kit
- **DMI:** Used to connect the Trimble MX SCAN DMI kit (optional)
- **Ext.:** Used to connect other external devices. Pinout and signals are provided in the Appendix.



## Dimensions

All dimensions are in mm.

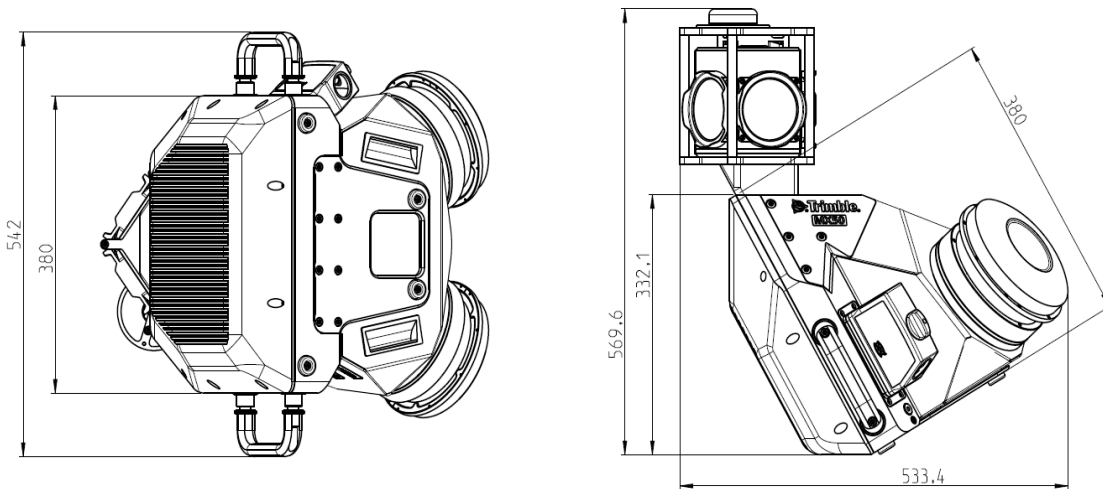

## Installing the Sensor Unit

Before installing the Trimble MX50 Sensor Unit, make sure the MX SCAN Roof Rack has been installed safely on the vehicle (see [Roof Rack](#), page 28).

The MX50 Sensor Unit should be installed by two people.

1. Before lifting up the MX50 Sensor Unit, make sure the safety locks of the MX SCAN Roof Rack are open. Use the tool stored in the Trimble MX SCAN Control Unit case for opening and closing the safety locks.

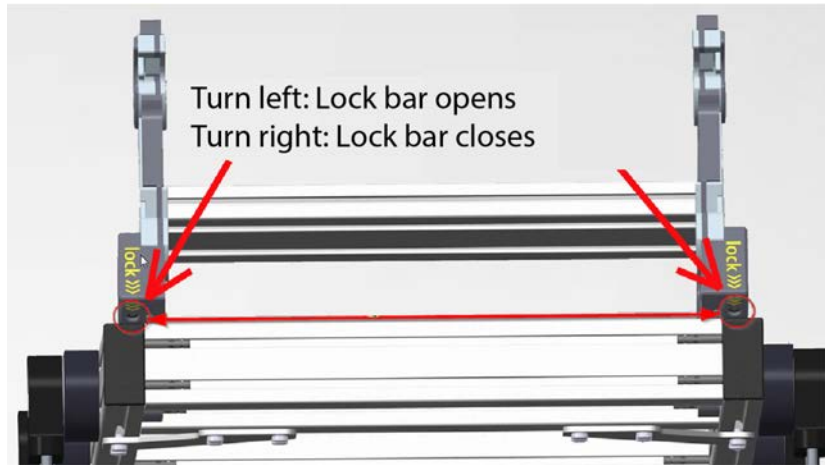

2. Then carefully lift the MX50 Sensor Unit (two people, four hands, one on each handle) and let the lower mounting bolts of the MX50 Sensor Unit slide into the lower mounting facilities of the MX SCAN Roof Rack.

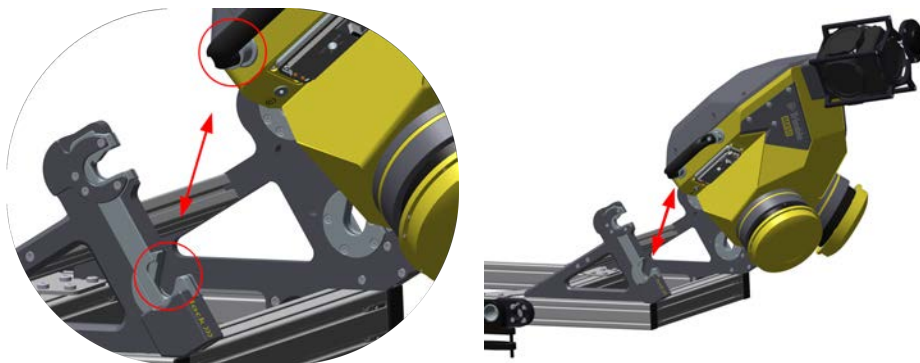



3. As the lower mounting bolts get in their final position, tilt the Sensor Unit ahead until the upper mounting bolts click in position and the fast lock of the Roof Rack mounting facilities is engaged.

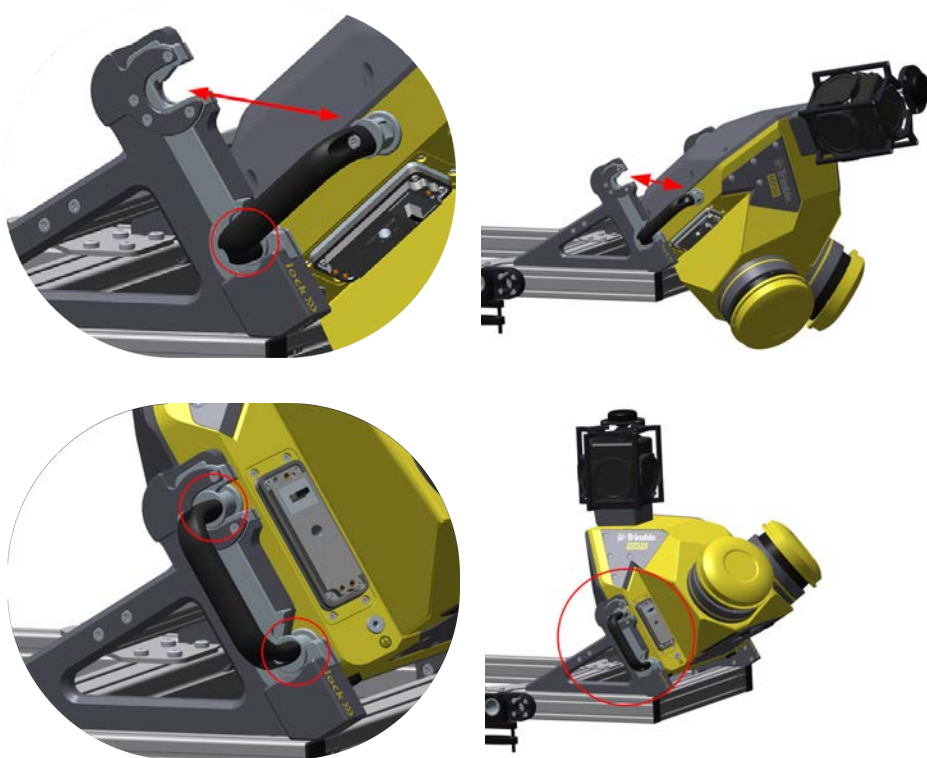

4. After the upper mounting bolts have “clicked” in their final position (fast lock), the Sensor Unit is stable and cannot turn over or fall from the Roof Rack. To finally secure the Sensor Unit, tighten the safety locks to close the lock bars (reverse action compared to what you did in step 1 above).
5. The MX50 Sensor Unit is now safely installed on the Roof Rack and cable installation can take place.





## Uninstalling the Sensor Unit

1. Remove cables.
2. Open the safety locks.
3. Release the fast locks by pressing the fast-lock button downwards.

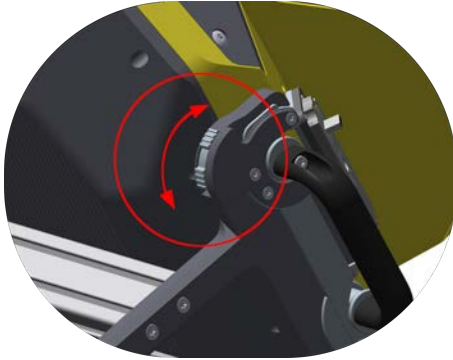

4. Turn the MX50 Sensor Unit (while pressing the fast-lock button) and remove the upper mounting bolts from their position.

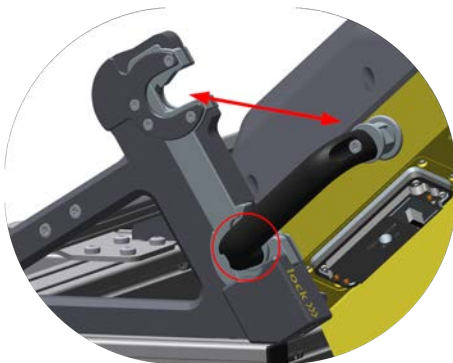

5. Lift the Sensor Unit out of the lower mounting facilities and place it safely in its transportation case.



## Control Unit

### Description

The MX SCAN Control Unit is the central computer unit as well as the man-machine interface for the MX50 system.



The control panel of the MX SCAN Control Unit includes the following elements:

#### 1. Power In Connector

This connector is used to connect the "MX SCAN Power Unit to Control Unit" cable through which power is provided to the Control Unit from the Power Unit.

## 2. Connector for “MX SCAN Control Unit to Sensor Unit” Cable

Power and signal interface with the Trimble MX50 Sensor Unit is achieved by making this connection. Before plugging in the cable, please make sure you use the correct end of the cable and all the pins are in good state.

## 3. On/Off Button

The On/Off button is used to start up the system. To avoid unintended start-up of the Trimble MX50 system, the On/Off button must be pressed for a minimum of 15 seconds before the system can initiate a start-up sequence.

## 4. Status LEDs for Control Unit, Sensor Unit and Wi-Fi Status

The different LED statuses have the same meanings for the three components:

- Blinking green: Component is being started, updated or shut down
- Solid green: Component is ready
- Blinking red: Component failed.

## 5. Exchangeable Data Disk

The Exchangeable Data Disk is the storage media for the collected data:

- Data Disk 1: Data from the 360° spherical camera, navigation and laser devices
- Data Disk 2: Empty slot (dummy SSD carrier)

## 6. Wi-Fi-USB-Stick 1

The Wi-Fi-USB-Stick 1 could be used for a Wi-Fi connection that allows the control device (tablet computer/laptop) to wirelessly operate the Trimble MX50 system.

## 7. Wi-Fi-USB-Stick 2

With the Wi-Fi-USB-Stick 2, the Trimble MX50 system could be connected to a hotspot/Wi-Fi network, thus allowing the Trimble MX50 system to access the Internet. This connection could be used for remote support as well.

## 8. LAN Connector

The LAN connector is used to connect the operating device (tablet computer/ laptop) to the Trimble MX SCAN Control Unit thus providing full control over the Trimble MX50 system.

## 9. WAN Connector

The WAN Connector can be used to connect the Trimble MX50 system to the Internet. This connection can also be used for remote support.

#### 10. **USB 2 Connector**

The USB 2 connector is reserved for use by the Trimble Support Team only.

#### 11. **USB 1 Connector**

The USB 1 connector can be used to:

- Provide the system with the required software
- Update the system license

#### 12. **Grounding Point**

To make sure the Trimble MX SCAN Control Unit is grounded in the same way as the other components of the Trimble MX50 system, a grounding cable (not included) can be used. The cable can simply be attached using the M5 knurled head screw (provided).

#### 13. **Fuses** (Circuit Breaker 1 for Control Unit, Circuit Breaker 2 for Sensor Unit)

The Trimble MX SCAN Control Unit and Sensor Unit are each protected by a circuit breaker inserted in the power input circuit. In the Control Unit, the two circuit breakers are located underneath the fuse cover. To reach the circuit breakers, you just have to remove the cover.

After reactivating one of the circuit breakers and before turning the system back on, check all the cables to make sure the problem was not due to a damaged cable.

## Dimensions

All dimensions in the drawing are in mm.

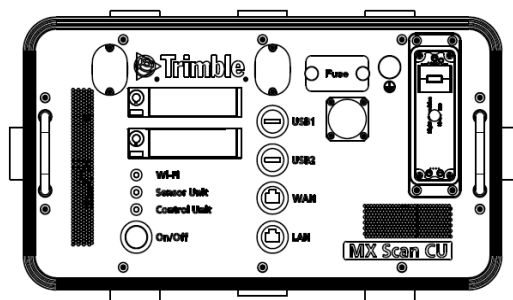
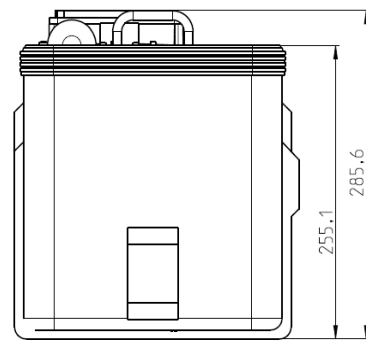
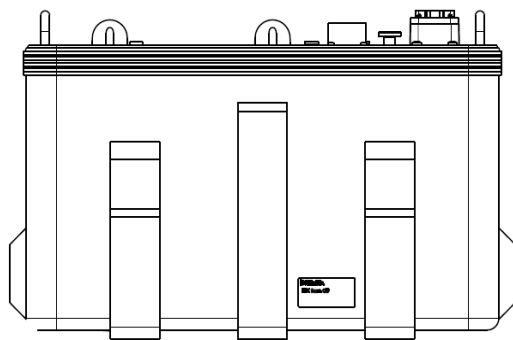
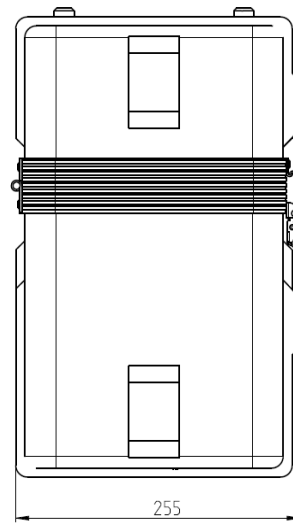
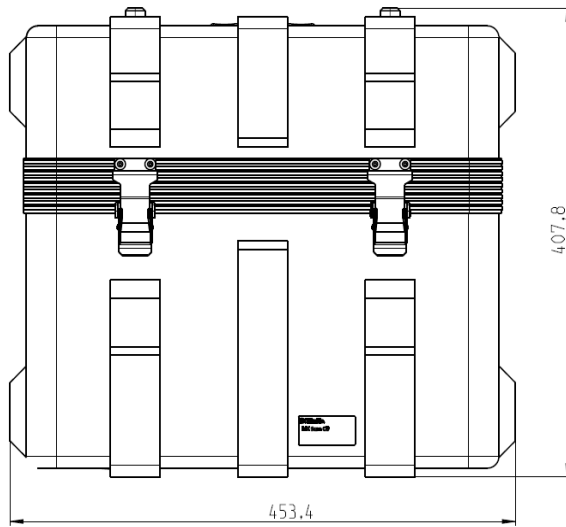

## Installation

The MX SCAN Control Unit should be installed where the operator can have reasonable access to the Data Disc and where the Status LEDs on the unit can readily be seen.

Accessibility is strongly depends on the installation choices you make, the model of the vehicle used, and the operator preferences. The only restriction in installing the unit on board the car is the length of the cable connecting the MX SCAN Control Unit to the MX50 Sensor Unit. The length of that cable (“MX SCAN - Cable - 5m, Control Unit to Sensor Unit, STD”) is 5 meters.

To install the MX SCAN Control Unit, first remove the cap from the unit, then place the unit where planned and secure it.

Flexible installation is also possible using the two belt guides (one on the front side, the other on the back side) through which a belt or a band may be inserted to secure the MX SCAN Control Unit to the required location.



For Safety Regulation, see [Safety Instructions, page 7](#).

## Power Unit

### Description

The MX SCAN Power Unit operates as the interface and power converter between the vehicle's battery and the MX SCAN Control Unit. The Power Unit also acts as a filter to protect the equipment from any possible electrical disturbance (spikes, etc.) coming from the car's alternator.

The "Source to Power Unit" cable (T001751), 5 meters long, is used for connecting the MX SCAN Power Unit to the vehicle's battery.

See details and specifications in the "Technical Parameters" section and in "Typical Installation of a Power Supply for MX50 in a vehicle" in the Appendix.



The front panel of the Trimble MX SCAN Power Unit includes:

- Power In (IN) connector, where the vehicle's power supply is plugged in
- Power Out (OUT) connector, provides power to the Trimble MX SCAN Control Unit
- Status LED, indicates that power is available on the Power Out (OUT) connector when the MX50 system is started using the Power button on the Control Unit. Note that the LED may stay ON for some time after the system has been powered off.
- Grounding Point, where a grounding cable can be fixed with an M5 screw.
- 1 A fuse, T001497, protects the power control line between the MX SCAN Power Unit and the MX SCAN Control Unit.

The bottom plate of the Trimble MX SCAN Power Unit includes:

- 30 A Fuse, T001289, protects the Power Unit regarding wrong polarization connection of the "Source to Power Unit" cable to the vehicle's battery



---

**⚠ WARNING** – The MX SCAN Power Unit is also equipped with two air vents (one at the bottom, the other at the back) as well as three mounting points to safely secure the Trimble MX SCAN Power Unit in the vehicle. NEVER COVER THE VENTS!

---

The Trimble MX SCAN Power Unit needs a minimum amount of power to operate in standby mode:

Power Consumption in Standby Mode	6.2 mA @13.8 V DC
-----------------------------------	-------------------

If the MX50 system is used on a daily basis, the MX SCAN Power Unit can be kept connected to the vehicle’s power supply.

If the MX50 system is not used for a longer period of time, the MX SCAN Power Unit should be disconnected from the vehicle to save the vehicle’s battery.

## Dimensions





2 System Overview and Installation

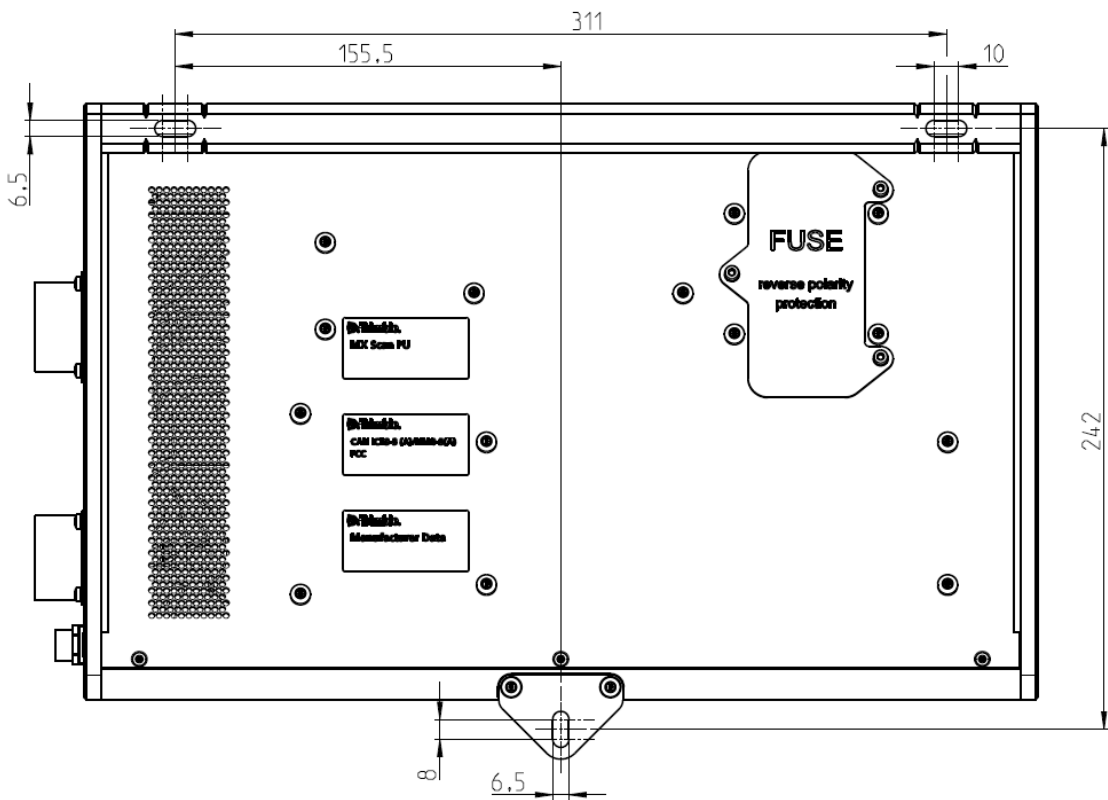
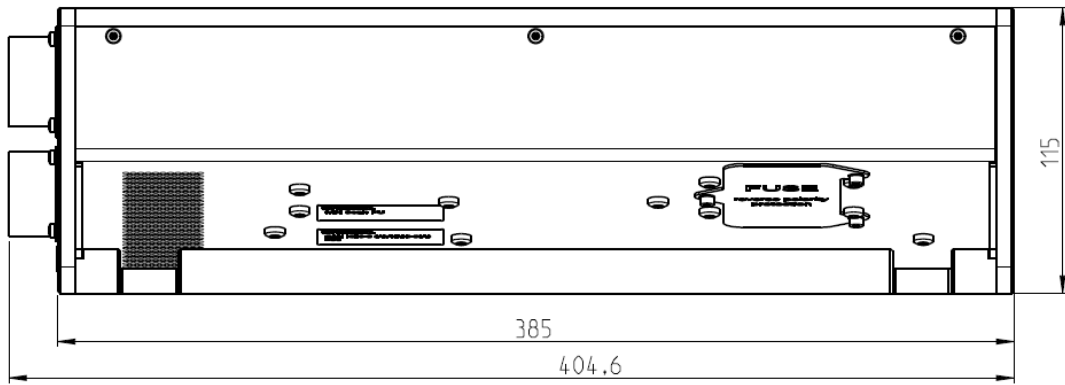

## Properties and Functionality

- Provides power required for the MX50 system.
- Protects the MX50 system from possibly defective vehicle's battery.
- Protects vehicle's battery from going low. The MX SCAN Power Unit is equipped with a Battery Protect that creates a sound warning signal to alert the operator when the battery drops below 10.5 V for longer than 12 seconds. The Battery Protect cuts off the power if the battery remains below 10.5 V for more than 90 seconds. Normal status is recovered if the voltage rises above 12.0 V during these 90 seconds.
- Indicates when power is available on the Power Out (OUT) connector (LED status is then solid green).
- Is controlled by the On/Off button on the Control Unit. To protect the system from unintentional power-on sequence, the On/Off Button on the MX SCAN Control Unit must be pressed for a minimum of 15 seconds.

## Installation

Like for all components of the Trimble MX50 system, the installation of the MX SCAN Power Unit strongly depends on the installation environment and the vehicle used or preferred.

Due to this, the final installation is under the responsibility of the customer in relation to the vehicle used.

The MX SCAN Power Unit can and should be tightly installed using the three mounting points (use screws with a diameter of 6 mm) inside the vehicle (e.g. in the trunk).

When installing the MX SCAN Power Unit, consider the following parameters:

- Install in a dry place within the vehicle.
- Secure the installation (use the mounting holes in the housing for a safe installation using screws).
- ALWAYS keep clear space around the air vents on the back and bottom sides of the unit!
- Consider cable routing for Power In and Power Out connections (e.g. a cable 3 meters in length is used to connect to the MX SCAN Control Unit).
- NEVER COVER the MX SCAN Power Unit as this could lead to exceedingly high operating temperature.



## Roof Rack

### Description

The MX SCAN Roof Rack is the mounting facility for the MX50 Sensor Unit and is designed to fit on square cut universal roof load bars installed on the vehicle.

The position in length and height of the mounting brackets is adjustable (with some restrictions). It is also possible to level the MX SCAN Roof Rack if leveling is required because of installation restrictions or for some other reasons.

The MX SCAN Roof Rack consists of the following components:

1. **Mounting Brackets:** Used to fix the MX SCAN Roof Rack on the universal roof bars. These are adjustable on the mounting points so that the roof rack can be leveled and adjusted distance-wise
2. **Roof Rack Mainframe:** Is the main structure of the MX SCAN Roof Rack
3. **Mounting Facilities** for the MX50 Sensor Unit
4. **Safety Locks:** Used to firmly secure the MX50 Sensor Unit
5. **Lock Bars:** Used in conjunction with the safety locks
6. **Fast Locks:** Latches that get automatically locked in once the MX50 Sensor Unit has been properly inserted.

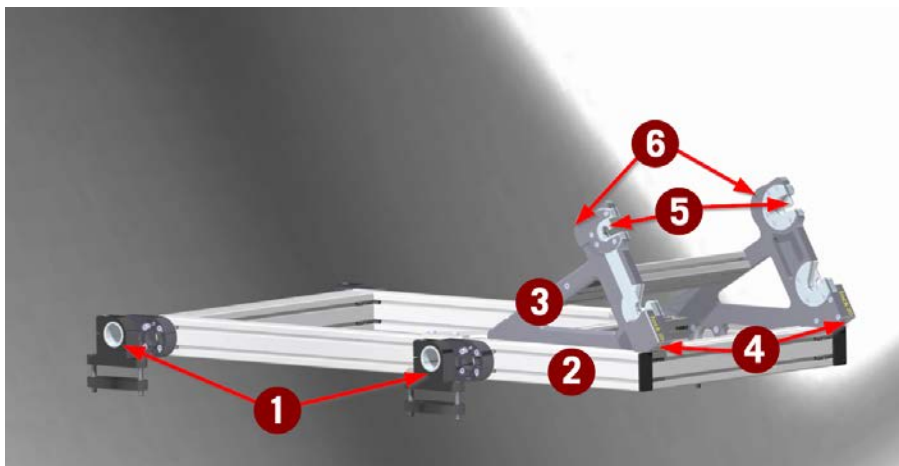

### Basic Requirement for a Car Roof

The roof rails of the car you have chosen to carry the MX50 system should be designed and specified to withstand the MX SCAN Roof Rack (18 kg), the MX50 Sensor Unit (23 kg) and the universal roof bars (whose weight depends on the model you choose).

## Basic Requirements for Universal Roof Bars

The MX SCAN Roof Rack is designed to fit on square cut universal roof bars having a width of up to 85 mm (see 1 in figure below) and a height of up to 30 mm (see 2 in figure below).

If your universal roof bars do not meet the height requirements, choose longer screws (ISO 4762 M8- A2).

Any installation other than the one using universal roof bars is possible provided it complies with the above requirements, which means you should make sure these requirements are met.



## External Reference Point

The MX SCAN Roof Rack also carries the External Reference Point of the system for lever-arm measurements. For more information, refer to [External Reference Point, page 44](#).

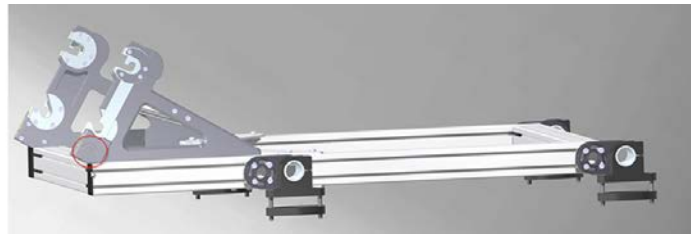

## Dimensions

All dimensions are in mm.

Parameters	Max Value
Maximum overhang	330 mm
Minimum space between mounting brackets	650 mm

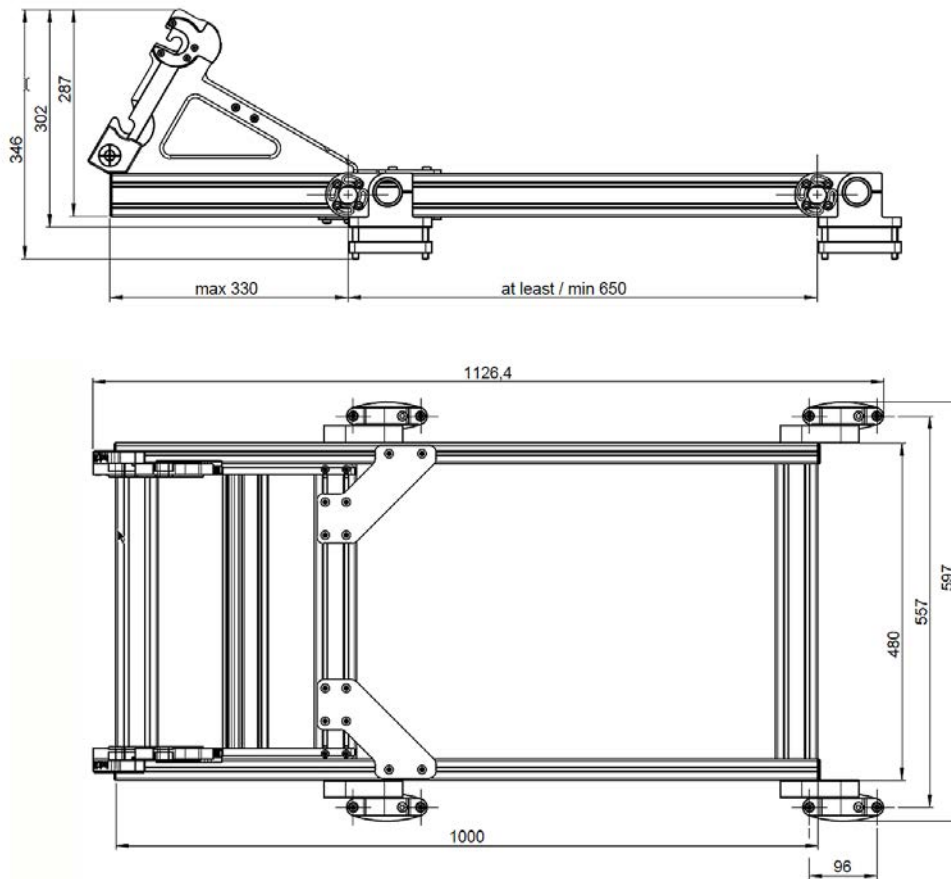

## Installation Restrictions

The MX SCAN Roof Rack is delivered pre-installed. The position and height of the brackets are adjustable, but with the two restrictions listed below:

- The overhang of the end of the MX SCAN Roof Rack to the back eye of the mounting bracket should not be greater than 330 mm.
- The distance between the eyes of the front and back mounting brackets should not be less than 650 mm. This minimum distance is indicated as a red marking (a stripe) on the mainframe.

## Adjusting the Position of the MX SCAN Roof Rack on the Roof Bars

Install the universal roof bars on the car. Please consider the restrictions described in section "Installation Restrictions".

To install the MX SCAN Roof Rack on the universal roof bars (see figure below):

- Loosen and remove the two main screws (1 and 2) on each mounting bracket.
- Remove the screw bridge (3).
- Put the MX SCAN Roof Rack on the universal roof bars (now installed on the vehicle).
- Put back the two main screws and the screw bridge together again, then tighten the screws to secure the MX SCAN Roof Rack. As this is a universal mount, there is no explicit torque recommendation for this mounting.

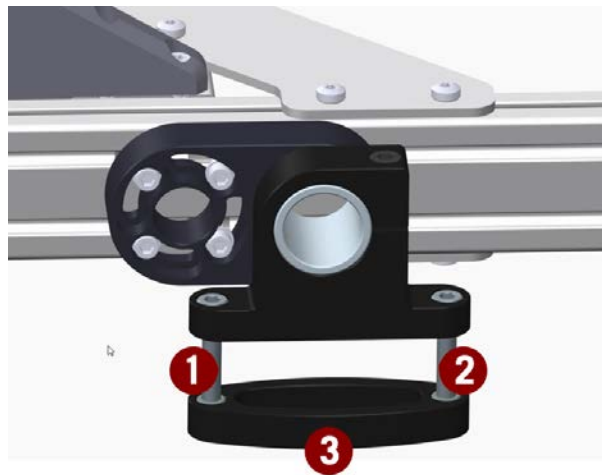

After the MX SCAN Roof Rack has been secured on the universal roof bars, the height, the overhang and the angle can be adjusted:

- **Overhang:** Loosen screws No. 5 on all mounting brackets and push the MX SCAN Roof Rack in the desired position (Please consider the restrictions). Then re-tighten screws No. 5 using a

torque value of 8 Nm.

- **Height and Angle:** Loosen screws No. 4 and No. 5, turn shaft block No. 7 around bracket shaft No. 6 to reach the desired angle, or at least the desired height. Then re-tighten the screws, complying with the recommended torque values:
  - Screws No. 5: 8 Nm
  - Screws No. 4: There cannot be any torque value recommended as the grip of the rivet is infinite.

Tighten all the screws evenly and crosswise (in the order mentioned below) in at least three runs to get the required torque value.

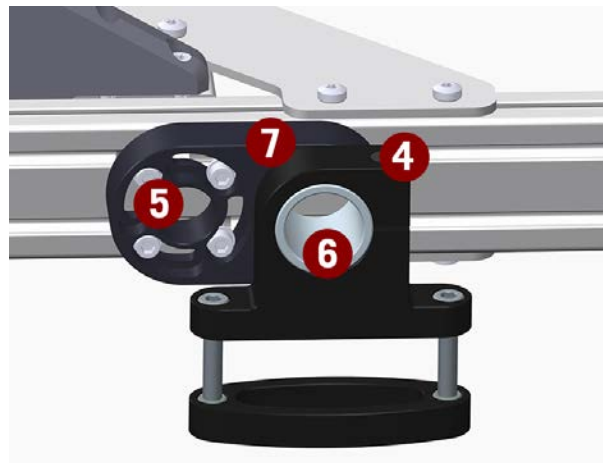
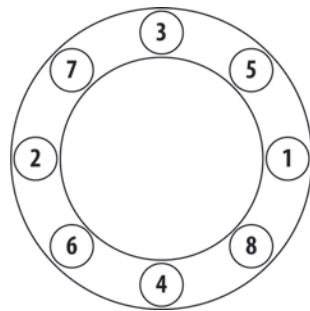



## Cables - Identification & Installation

**NOTE** – Before making any cable connection, please read the [Safety Instructions, page 7](#).

The MX50 system is delivered with three different cables. These should be used and connected as indicated below:

1. **Source-to-Power-Unit Cable, 5 meters:**



Connect this cable between the MX SCAN Power Unit and the power source available on board the vehicle. For more details on a typical installation, refer to [Installing a Power Supply in a Vehicle for Safely Operating the MX50 System, page 60](#).

2. **Power-Unit-to-Control Unit Cable, 3 meters:**



Connect this cable between the MX SCAN Power Unit and the MX SCAN Control Unit. Both power and signals are routed via this cable.

Additionally, connect the ground terminal of the three units of the MX50 to the vehicle chassis. All ground connections for the Trimble MX50 components are under the control and

responsibility of the system owner and are dependent on the installation environment specific to the vehicle.

3. **Control-Unit-to-Sensor-Unit Cable, 5 meters, STD:**



Each end of this cable uses a specific connector type. Make sure you hold the right end of the cable before inserting it into a unit. You should also make sure the pins on each of these two connectors are in good state (the pins should not be bent or broken).

- Connect the "Sensor Unit" end of the cable to the Trimble MX50 Sensor Unit.
- Slide in and secure the Sensor Unit Side of the cable by turning the lock screw to the right. The lock screw is colored black and located on top of the connector.
- Install and secure the cable safely (in relation to the vehicle and the installation environment).
- Plug the other end (the "Control Unit" end) of the cable to the Trimble MX SCAN Control Unit. Also slide in and secure this end of the cable by turning the lock screw.

- The plugs used at the ends of this cable are design to withstand up to 1,500 mating cycles.



## User Interface Device

The MX50 system is operated from a mobile device. This can be a tablet computer or a laptop, ideally with a touch display.

The device should have at least the following specifications:

- Fitted with a 10" (or larger) display
- Ideally fitted with a touch display (laptop and mouse may work as well, but might be unhandy considering that the system is used in a vehicle moving at normal road speeds)
- Google Chrome for running the Trimble Mobile Imaging User Interface

The installation can take place where it is comfortable for the operator. Note that the driver is not allowed to operate the system and should not be distracted by the whole equipment. It is recommended that the system be operated by a second person (the operator).

Ensure that the tablet computer or laptop is mounted and stored as advised in its manual.

## Connecting the Device via the Ethernet

For connecting the user interface device to the MX50 system via Ethernet, an active network port should be made available on this device and should be set as follows:

- **Obtain an IP address automatically** check box enabled.
- **Obtain DNS server address automatically** check box enabled.

(See below the typical Windows dialog to make these settings.)

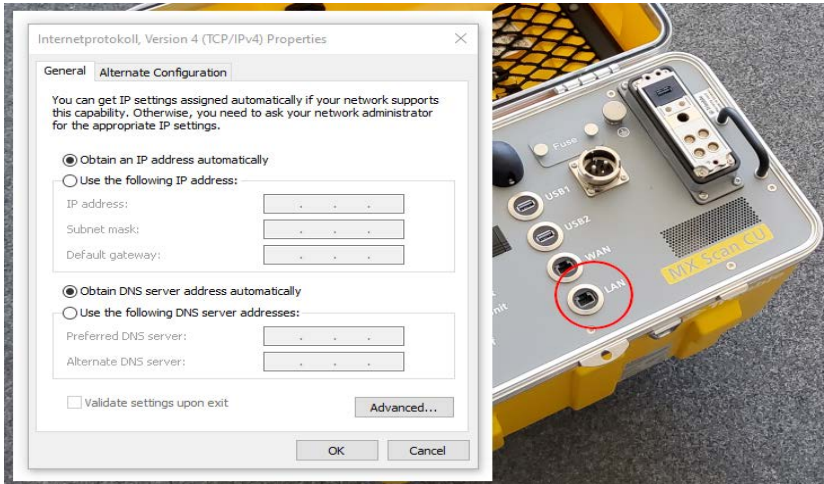

A standard Ethernet cable, fitted with an RJ45 connector, should be connected to the LAN port on the Control Unit ( see 8 on the above picture).

## Connecting the Device via Wi-Fi

When scanning for available Wi-Fi networks, the MX50 system should show up in the list of detected devices.

The SSID of the MX50 system is in the form: "Trimble MX50 (117070101)", where the number within the brackets is the serial number of the MX50 system.

The password to connect to the MX50 Wi-Fi is provided on separate stickers shipped inside the transportation case of the MX50 Sensor Unit. This password is unique for each system and cannot be changed.

See also *TMI Software User Guide - Establishing Network Connection*.

## Storage and Transportation

### Delivered Items

The MX50 System is delivered in two different boxes:

1. **Box 1.** This shipping box includes:

- The Trimble MX50 Sensor Unit in its storage case. The dimensions of the storage case are (L x W x H): 806 x 716 x 634 mm.
- The *Control-Unit-to-Sensor-Unit* cable, 5 meters, also included in the storage case.

See picture below (storage case open, shipping box not shown; the storage case also includes a hex wrench, a Quick Start Guide and three copies of a sticker providing the Wi-Fi password).

- Hex wrench 6 tool



## 2 System Overview and Installation

2. **Box 2:** This shipping box includes the following items:

- Trimble MX SCAN Roof Rack



- Trimble MX SCAN Power Unit

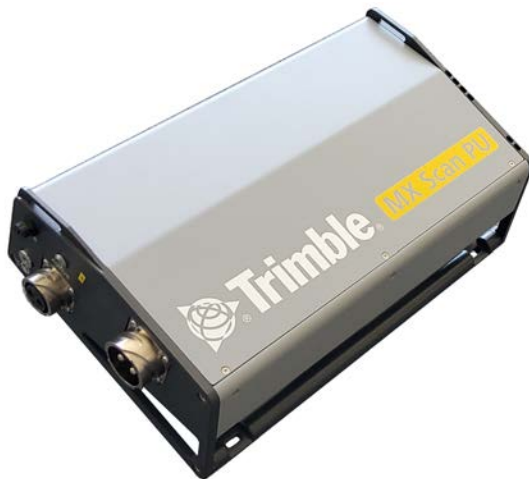

- Trimble MX SCAN Control Unit





This unit has no transportation case as such, but once you have fastened the lid onto it, it can safely be transported without the need for a specific transportation case. You will also find the following items inside the Control Unit transportation case (see also previous picture):

- Stickers of the 'MX SCAN Label WIFI Code'
- USB 3.0 Cable (for Data Storage Disk)
- Keys for Data Storage Disk
- Quick Start Guide
- SSD Drive (installed in the Control Unit)
- Trimble GAMS Antenna Kit
- *Source-to-Power-Unit* cable
- *Power-Unit-to-Control-Unit* cable.

In box 2, these items are organized as shown on the picture below.



Where:

- 1: Power Unit
- 2: Control Unit
- 3: Roof Rack
- 4: Trimble GAMS Antenna Kit
- 5: Cables

Box 2 weighs 75 kg and has the following dimensions (L x W x H): 1170 x 770 x 500 mm.

## Use Assumptions

Trimble assumes the different components of the MX50 system are used as follows:

- The Roof Rack is permanently installed on the vehicle roof.
- The Power Unit is permanently installed inside the vehicle.
- The *Source-to-Power-Unit* cable is permanently installed inside the vehicle.
- The Control Unit is temporarily installed in the vehicle just for operation.
- The Sensor Unit is temporarily installed on the Roof Rack and removed for transfer<sup>1</sup>. The GAMS Antenna Kit and its cable are temporarily installed and removed for transfer if the Sensor Unit has been removed.
- External instruments (e.g. DMI) as well as the cabling for these instruments are removed for transfer and storage.
- Cables between Power Unit and Control Unit and between Control Unit and Sensor Unit temporarily installed in and on the vehicle for operation and removed for storage and transfer.

Whenever the Trimble MX50 system is not used (storage, transportation or transfer), the Sensor Unit must be stored in its storage case and the Control Unit must be closed by placing its lid back on.

## Storage

Storage conditions are provided in the Technical Parameters section of this manual. See [Environmental](#), page 52.

---

<sup>1</sup>"Transfer" refers to that period of time during which the vehicle is driven without operating the MX50 system, although it's still installed in the vehicle (except for the Sensor Unit which should have been removed from the roof).



## Optional Accessories

### DMI

The “Trimble MX SCAN DMI Kit” T001507 is an additional mechanical assembly group allowing you to use the DMI (Distance Measuring Indicator) functionality with the Trimble MX50 system.

To improve the measurement accuracy of the Trimble MX50 system, this additional sensor can be used (Zero Velocity Update (ZUPT) information for navigation postprocessing).

For more information about the Distance Measuring Indicator, refer to the *Trimble DMI Installation & Operation Manual* or contact your Trimble dealer.



## GAMS

The "Trimble GAMS Antenna Kit" is a mechanical assembly group allowing you to use the GAMS (GNSS Azimuth Measurement System) functionality with the Trimble MX50 system.

GAMS is an additional GNSS antenna used in the field to speed up the initialization of the navigation system, hence of the MX50 system. Thanks to the second GNSS antenna, the orientation of the car can be estimated far more quickly compared to what can be achieved with a single-antenna solution. For more details, please contact your Trimble dealer.

For more information about the GNSS Azimuth Measurement System, refer to the *Trimble GAMS Antenna Kit Installation & Operation Manual*.

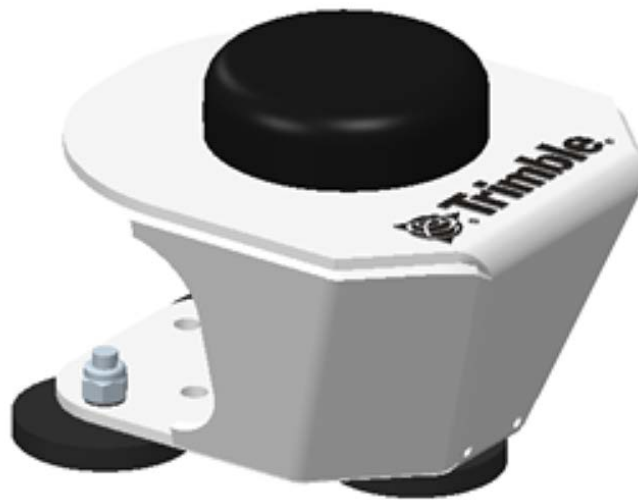

To connect the GAMS kit to the MX50 system, use the "Ant." connector on the MX50 Sensor Unit.

# Operation

## Safety Check

- Complete a safety check before and after each mission
- All broken or damaged components should be exchanged immediately.
- All loose screws should be tightened.
- Any screw must be tightened with the correct torque value as mentioned in the System Overview and Installation chapter. Be aware of the appropriate procedure to tighten screws
- Any dirty or wet part should be cleaned or dried.
- Do not start a mission before solving any issue you may have had previously with the system. Not doing this may damage the system permanently.
- The operator must take care to fulfill all requirements and certifications.

## Components Checklist

- Check that the MX SCAN Roof Rack is installed correctly:
  - Check that all the screws of the MX SCAN Roof Rack have been tightened.
  - Check that the MX SCAN Roof Rack components show no cracks or deformation.
- Check that the MX50 Sensor Unit is damage-free (no scratches or deformation of material):
  - Check that all camera lenses and laser windows are clean and not damaged in any way (scratches or marks).
- Check that the MX50 Sensor Unit is in operation position and properly locked.
- Check the Control Unit for damages or any broken parts.
- Check that the Control Unit is installed correctly and secured.
- Check that the Power Unit is damage-free, and there is no broken part.
- Check that the Power Unit is installed correctly, air inlet and air outlet are free and the Power Unit is secured.

- Check all cable connections:
  - Check that the connectors are plugged in and fixed.
  - Check that the cables are fixed to the vehicle roof rack before being led inside the vehicle cabin.
  - Check that no cable is damaged or might get damaged during operation.
- Check that the user interface device (laptop, tablet, etc.) is operational.

## External Reference Point

The MX50 system needs to know how it has been mounted on the vehicle and how the external components have been mounted relative to the MX50. These mounting measurements are listed below:

- **Installation Height:** Height of the MX50 system above the road surface
- **DMI Lever Arm:** Three-axis distance between the MX50 system and the DMI (wheel sensor)
- **GAMS Lever Arm:** Three-axis distance between the MX50 system and the secondary GNSS antenna.

## Measuring Installation Parameters and Lever Arms

All these measurements are performed from the MX50 system's External Reference Point to the corresponding counterpart. The **External Reference Point** is located on the right side, at the back of the MX SCAN Roof Rack.



The **Installation Height** is measured from the External Reference Point down to the road surface. The value is always given in meters as an absolute value.

**Lever Arm** measurements for DMI and GAMS are performed in the so-called Vehicle Frame from the External Reference Point to the center of the corresponding sensor (DMI or GAMS) as measurements of distance (also in meters) along three different axes. The orientation of the axis in the vehicle frame is defined as follows:

Positive X-axis	In forward driving direction
Positive Y-axis	Right side of vehicle
Positive Z-axis	Downward

**⚠ CAUTION** – Make sure you are using the correct sign when measuring Lever Arm values. For example, a DMI mounted on the left wheel has a negative Y Lever Arm value.

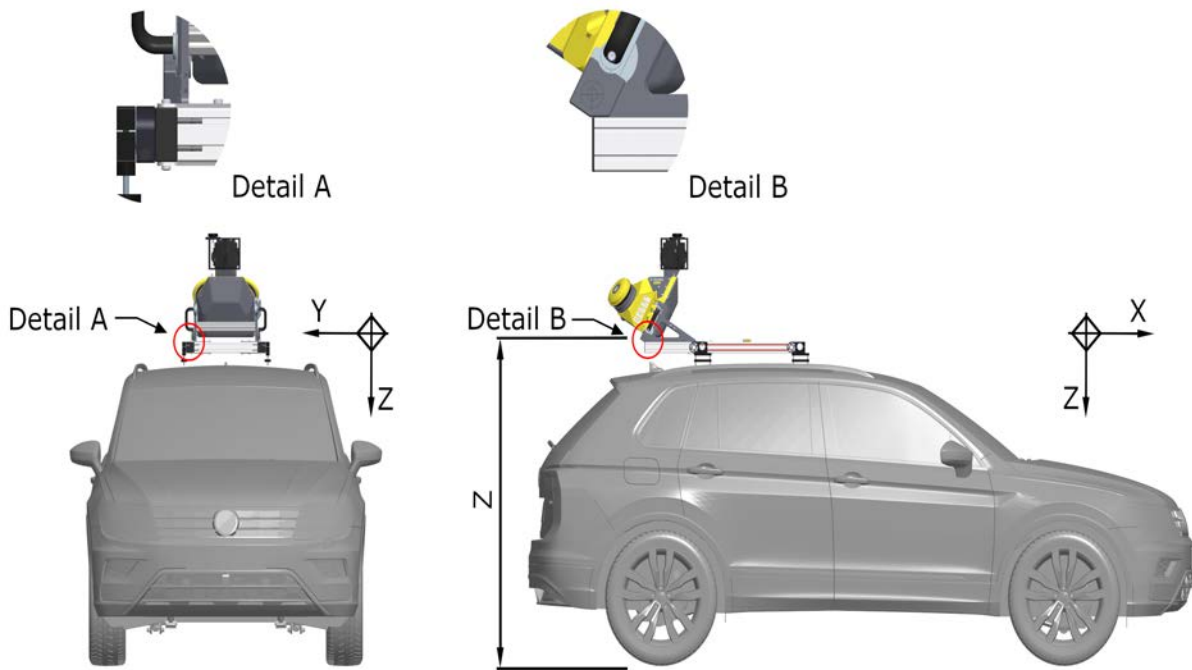

### *Additional Note for DMI*

The DMI Lever Arm is a three-dimensional vector defining the offset from the External Reference Point to the sensing center of the DMI. This offset vector is measured in the Vehicle Frame. Lever distances are measured from the External Reference Point to the center of the tread (where the DMI-equipped wheel makes contact with the road). The DMI-equipped wheel must be a non-steering wheel.

### *Additional Note for GAMS*

The GAMS Lever Arm is a three-dimensional vector defining the offset from the External Reference Point to the GAMS Antenna. This offset vector is measured in the Vehicle Frame. Lever distances are measured from the External Reference Point to the Antenna Phase Center of the GAMS Antenna (secondary GNSS Antenna).

## Configuring the MX50 system for Operation

All parameters mentioned above need to be measured after having installed the MX50 system and all the additional sensors (DMI, GAMS) on the vehicle. In the next step, the measured numerical values need to be stored as the Vehicle Preset in the TMI Software, which is used to configure the system before a mission is started.

---

 **CAUTION** – Using incorrect or poor measurement values in the Vehicle Preset may result in faulty navigation solutions. Make sure that all values are entered correctly (on the order of 1 cm). Later on, make sure you select the correct Vehicle Preset before starting a mission.

---

### *Additional Note on POSPac Processing*

The origin of the MX50 System Reference Frame is different from the External Reference Point. For this reason, the TMI Software adds additional internal vectors to the Lever Arm values provided in a Vehicle Preset. In POSPac processing, you will be able to read the corrected Lever Arm values and you will see that they are different from the mechanical measurements.

## Prerequisites to System Setup and Operation

---

 **CAUTION** – Before starting, please make sure all connections are secure and the recording SSD is inserted in the SSD1 slot and both slots are locked.

---

Before starting data capture, make sure the measurement parameters (e.g. sensor setup on the vehicle and capture parameters) have been set properly. The parameters you have defined may be saved as presets under user-defined names and can be selected when starting a mission later.

A standard operation workflow and an “In-the-field operation checklist” are described more in detail in the *Trimble MX50 Quick Start Guide*.

---

 **WARNING** – The first time you use the Trimble MX50 system, and then every time you start a data collection campaign in a different country, you must specify the name of this country when setting the Wi-Fi access point. This is a mandatory prerequisite. That way, you are sure to comply with the regulations of this country in terms of Wi-Fi use. To set the country of use, run the TMI Software, then in the menu, select **System Administration / WiFi / MX50 WiFi Access Point** and then choose a country.

---

## System Software

The software running the MX50 system is called TMI. It is described in a separate manual, *Trimble TMI Software for Trimble Mobile Mapping Systems User Guide*.

# 4

## Maintenance and Support

### Maintenance

Dismantling or attempting to have a MX50 system repaired by unauthorized personnel can be hazardous and costly. Maintenance should be limited to the cleaning and inspection of external surfaces, lens glass, operating controls, etc.

### Preventive Maintenance

The preventative maintenance to be carried out by the operator should include:

- During use:
  - Avoid operating the system in rainy or misty weather.
  - Avoid mechanical shock.
  - Clean and dry the equipment before, during and after use if necessary.
- Before storage:
  - Dry the system thoroughly before storing.
  - Correctly pack the equipment in the transportation / storage case provided.
  - Ensure the transportation / storage case is kept dry and clean inside.
  - Ensure that your equipment is dry before storage.
  - Store within the equipment environmental temperature and humidity limits.
- During transportation:
  - Correctly pack the equipment in the supplied transportation cases.
  - Do not allow the equipment to slide around inside transport vehicles or containers.
- General:
  - Carry out regular functional testing of the system.
  - Detect and report damage, malfunctions and poor performance.



## Lubrication of Movable Parts

The lock bars as well as the fast lock mechanism of the Roof Rack should be cleaned and re-lubricated frequently. After cleaning, simply use a spray oil for re-lubrication.

## Cleaning the Camera Lens Glass and Laser Glass

- Perform all cleaning operations in a clean environment.
- To remove dust and dirt, first try to gently blow the debris off with an air compressor.
- If the debris will not come off using an air compressor, apply a small amount of optics cleaner (e.g. Photographic Solutions Eclipse Optics Cleaner) or ethyl alcohol to a clean lens cloth (e.g. Pentax lens cloth). The cloth should be moist but not dripping.
- Wipe the cloth or swab along the length of the glass surface in smooth movements. Do not press hard on the surface or rub repeatedly on one spot.
- If pooling or streaks occur, there may be too much solution—wait for it to dry, then repeat.
- When finished cleaning, examine the glass surface in light.
- If dust spots remain, repeat this procedure using a clean lens cloth.

## Support

### General

If you need support for the Trimble MX50 or Trimble Mobile Mapping software, please contact our Customer Support team via email:

**Trimble Support Email** [imaging\\_support@trimble.com](mailto:imaging_support@trimble.com)

Or call:

APAC: +86 1 088 5775 75824

Americas: +1-289-695-4416 or +1-303-635-9200

EMEA and ROW: +49-7351-474-0237

Please describe the issue you are facing as precisely as possible:

- Short description of the problem
- Workflow and how to reproduce the problem
- If occurring during a mission:
  - Location of the mission.
  - Environmental conditions.

Also send the following information about your Trimble MX50 system:

- System log file
- Serial number
- Total operating hours of your Trimble MX50 system since purchase.
- Photos or videos may also be useful to report a problem

### Trimble Land Mobile Download Center

System software updates, FAQs, and documentation are available in the Trimble Land Mobile Download Center.

Documentation for the Trimble MX50 system can be found at <https://geospatial.trimble.com/products-and-solutions/trimble-mx50>.

# Appendix

## Technical Specifications

### MX50 System

#### *Power Requirements*

Parameter	Value	
Input Voltage Range:		
MX50 Dual Head Spherical	12 V to 16 V	DC (150 W typical)
DC Current: <sup>1</sup>	In Operation	Startup
MX50 Dual Head Spherical	12 A @ 12,8 V	25A @ 12,8V DC

---

<sup>1</sup>Depends on temperature.

## Weight

Parameter	Value
MX50 Dual Head Spherical	23 kg
MX SCAN Control Unit	12 kg
MX SCAN Power Unit	9 kg
MX SCAN Roof Rack	18 kg
Source-to-Power-Unit Cable, 5 meters	2 kg approx.
Power-Unit-to-Control Unit Cable, 3 meters	1.5 kg approx.
Control-Unit-to-Sensor-Unit Cable, 5 meters, STD	3.5 kg approx.

## Environmental

Parameter	Value
Operating Temperature Range <sup>1</sup>	-10 °C to +50 °C (14 °F to 122 °F)
Storage Temperature Range	-20 °C to +50 °C (-4 °F to 122 °F)
Operating Relative Humidity Range <sup>2</sup>	10 % to 80 %
Storage Relative Humidity Range	20 % to 95 %
IP Rating	IP64 (Sensor Unit) IP30 (Power Unit and Control Unit)
Maximum Vehicle Speed (with operating or non-operating system on board)	110 km/h (68 mph)
Recommended Maximum Vehicle Speed (with operating system on board)	80 km/h (50 mph)

<sup>1</sup>Not exposed to direct sun and without driving less than 10 km/h (6 mph).

<sup>2</sup>Non-condensing.

## Spherical Camera Performance

The spherical camera system included in the Trimble MX50 Sensor Unit consists of six single cameras that deliver a spherical image. The performance data of the cameras, as applied in the MX50, are given below.

Parameter	Value
Image resolution (total)	30 megapixels
Image format	PGR (compressed JPEG)
Shutter system	Global shutter
Focal length	4.4 mm
Focus distance	About 2.0 m (sharpness from 0.7 m to infinity)
Field of view	90 % of full sphere
Number of single cameras	6
Image resolution of single cameras	5 Megapixels
Sensor type	CMOS
Sensor size (single camera)	2/3"
A/D converter	8 bits

## Laser Performance

The Trimble MX50 Sensor Unit includes two scanner units. The scanner consists of a pulsed laser (time-of-flight measurement) and a rotating mirror.

Each of the scanners provides a beam deflection of ~346°.

## Scanner and Laser Specifications

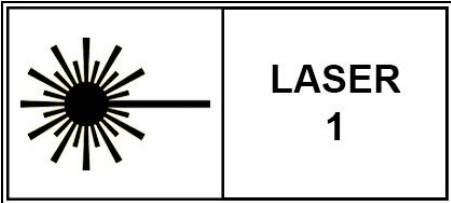
Parameter	Value	
Measurement Principle	Time-of-flight measurement	
Laser Pulse Repetition Rate PRR <sup>1</sup>	166 kHz	500 kHz
Max. Measurement Range <sup>2</sup>	80 m	80 m
Minimum Range	0.6 m	
Range Accuracy <sup>3 4</sup>	2 mm	
Precision <sup>4 5</sup>	2.5 mm @ 30 m	
Scan Speed (No. of profiles per second)	120 Hz	
Laser Beam Footprint (Gaussian Beam Definition)	2.8 mm @ exit	
Laser Wavelength	Near Infrared	
Laser Product Classification <sup>6</sup> according to IEC60825-1:2014		

<sup>1</sup> Rounded values.

<sup>2</sup> Typical values for average conditions. Maximum range is specified for flat targets with size in excess of the laser beam diameter, perpendicular angle of incidence, and for atmospheric visibility of 23 km. In bright sunlight, the maximum range is shorter than under overcast sky.

<sup>3</sup> Accuracy is the degree of conformity of a measured quantity to its actual (true) value.

<sup>4</sup> One sigma range under test conditions.

<sup>5</sup> Precision, also called reproducibility or repeatability, is the degree to which further measurements show the same result.

<sup>6</sup> The classification is based upon the assumption that the laser beam is continuously scanned.

## POS System Performance

The Trimble AP60 and AP20 feature a high-performance, precision GNSS receiver and the industry-leading, Applanix IN-Fusion™ GNSS-Inertial integration technology running on a dedicated and powerful Inertial Engine (IE) board.

Assuming the best operation conditions regarding satellite configuration, atmospheric conditions and other environmental effects, the following performance with the DMI option can be achieved.

Ideal POS System Performance for AP60

Terrestrial Applications	No GNSS Outage		60-second GNSS Outage	
	SPS	Postprocessed <sup>1</sup>	SPS	Postprocessed <sup>1</sup>
Position (m)	1.5-3.0	0.02-0.05	1.5-3.0	0.07-0.10
Velocity (m/s)	0.030	0.005	-	-
Roll (degrees)	0.005	0.005	0.008	0.005
Pitch (degrees)	0.005	0.005	0.008	0.005
True Heading (degrees) <sup>2,3</sup>	0.020	0.015	0.050	0.015

Ideal POS System Performance for AP20

Terrestrial Applications	No GNSS Outage		60-second GNSS Outage	
	SPS	Postprocessed <sup>1</sup>	SPS	Postprocessed <sup>1</sup>
Position (m)	1.5-3.0	0.02-0.05	4,5 - 5,5	0,13 - 0,32
Velocity (m/s)	0.050	0.005	-	-
Roll (degrees)	0,030	0,015	0,030	0,020
Pitch (degrees)	0,030	0,015	0,030	0,020
True Heading (degrees) <sup>2,3</sup>	0,050	0,025	0,070	0,030

<sup>1</sup> Calculated with POSpac MMS.

<sup>2</sup> Typical mission profile, max RMS.

<sup>3</sup> With GAMS option, 2 m baseline.

## *Technical Specifications*

- Advanced Applanix IN-Fusion™ GNSS-Inertial integration technology
- Advanced Trimble Maxwell® 6 Custom GNSS survey technology (two chipsets)
- Primary Chipset:
  - GPS: Simultaneous L1 C/A, L2C, L2E, L5
  - GLONASS: Simultaneous L1 C/A, L2 C/A, L2 P
  - BeiDou: B1, B2
  - Galileo: Simultaneous L1 BOC, E5A, E5B
  - QZSS: L1 C/A, L1 SAIF, L2C, L5
  - SBAS: Simultaneous L1 C/A, L5
  - L-Band: OmniSTAR VBS, HP, XP and G2, Trimble CenterPoint RTX
- Secondary Chipset:
  - GPS: Simultaneous L1 C/A, L2C, L2E
  - GLONASS: Simultaneous L1 C/A, L1 P, L2 C/A, L2 P
  - BeiDou: B1
- High precision multiple correlator for GNSS pseudorange measurements
- Unfiltered, unsmoothed pseudorange measurements data for low noise, low multipath error, low time domain correlation and high dynamic response
- Very low noise GNSS carrier phase measurements with <1 mm precision in a 1 Hz bandwidth
- Data logging:
  - Time tag, status, position, attitude, velocity, track and speed, dynamics, performance metrics, raw IMU data (200 Hz)
  - Raw GNSS data (5 Hz)
- Proven Trimble low elevation tracking technology
- Support for optional Distance Measurement Indicator (DMI) input
- Support for optional POSpac Mobile Mapping Suite postprocessing software



## Abbreviations

The following table explains some of the acronyms and expressions used in this manual.

Abbreviation	Description
#SAT	The number of GNSS satellites being received by the GNSS receiver
Ah	Battery rating (Ampere hours)
DMI	Distance Measuring Indicator
fps	Frames per Second
GAMS	GNSS Azimuth Measurement System
Galileo	European GNSS system
GLONASS	Russian GNSS system
GNSS	Global Navigation Satellite System
GPS	Global Positioning System
IMU	Inertial Measurement Unit
IP	Internet Protocol
LED	Light Emitting Diode
PDOP	Positional Dilution of Precision
PWR	Power
PRR	Pulse Repetition Rate
RMS	Root Mean Square
SSD	Solid State Disk
SRR	Scan Repetition Rate
UTC	Universal Time Coordinated
VDC	Volts Direct Current
ZUPT	Zero Velocity Update

## Vehicle Requirements

### General

- Vehicle should be fitted with rubber wheels for use on paved roads
- No bright color to avoid exposure artefacts
- Room for system storage during transfer:
  - Dimensions of Sensor Unit transportation case: 806 x 716 x 634 mm (L x W x H)
  - Dimensions of Control Unit transportation case: 453 x 255 x 408 mm (L x W x H)
- Hatchback vehicle with upright rear door
- Minimum height of 1.60 m for the vehicle roof is recommended.

### Mechanical

- Roof rails should withstand the required roof load
- Required dimensions of roof wings to properly install the MX SCAN Roof Rack (width x height): 85 x 30 mm
- Roof rails should cover the entire roof so the scanner position can be adjusted in case of slightly unfavorable roof rail design
- Remember the maximum lengths for system cables:
  - Power-Unit-to-Control-Unit cable: 3 meters
  - Control-Unit to-Sensor-Unit cable: 5 meters
- Allow for mounting options for Power Unit and Control Unit inside the vehicle (these two units are NOT waterproof).

### Electrical

See [Power Requirements, page 51](#) and [Installing a Power Supply in a Vehicle for Safely Operating the MX50 System, page 60](#).

- Capable of delivering the required power
- Start/stop mechanism must be switched off
- Sufficient alternator power (or additional battery pack)

## Typical Installation Example



## Installing a Power Supply in a Vehicle for Safely Operating the MX50 System

To safely operate the MX50 system in a vehicle, a reliable 12 V DC power supply should be made available in the vehicle. See also [Power Requirements, page 51](#).

Typically this can be accomplished using the vehicle's own battery and charging system. With the help of a buffer battery, the MX50 system operation will be independent of the short-term behavior of the vehicle's electrical power management system.

---

 **CAUTION** – Please observe the following recommendations:

- Any installation and integration of a power supply in a vehicle must be done by a professional car electrician service and are under customer's responsibility and control.
  - All selected components (cable type, cable gauge, fuses, relay, etc.) have to be selected to be compliant with the MX50 input power requirements and with the local law and vehicle regulations.
  - Please consider car-related restrictions like for example, car battery & energy management (Auto On/Off, Energy Management Emission Level Euro 6 and higher, etc.) as well as any restrictions given by local law.
- 

The power input of the MX50 system should meet the following electrical requirements:

<b>Input Voltage Range</b>		12 to 16 V DC (150 W)
<b>DC Current</b>	At start-up:	25 A @ 12.8 V
	Steady-state operation:	12 A @ 12.8 V
<b>Battery Capacity</b>		60 Ah min.

## Typical Power Supply Setups

The two setups described below are designed with a relay, which only provides power to the connector when the alternator – and in this case the car engine – is running. This prevents the primary battery (i.e. the car battery) from going too low.

### Direct connection

(Only the car battery is used.)

In this scenario, the provided Source-to-Power-Unit cable (P/N T001751; 5 meters long), with its open end, can be connected directly to the fuse and to the relay. Both the fuse and the relay should be placed close to the battery, as shown in the electrical diagram below. The current rating of fuse 3 should be 35 A.



### Using a Buffer battery

(A buffer battery is used, in addition to the car battery.)

In this scenario, additional fuses (Fuse 1 and Fuse 2) are required as the buffer battery is also a power source. Fuse 1 should be placed as close as possible to the car battery and fuse 2 as close as possible to the buffer battery. As shown in the electrical diagram below, the provided Source-to-Power-Unit cable (P/N T001751) is then connected to Fuse 3 and to the buffer battery.

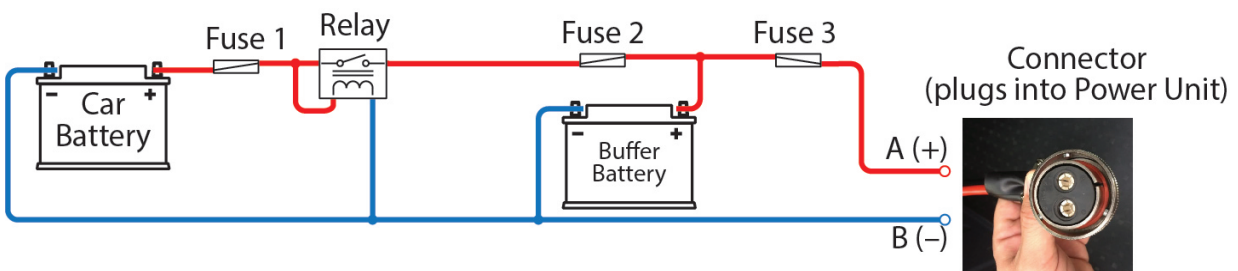

For more details, please contact Trimble Support.

## External-Signal Connector

This connector provides the possibility to time-synchronize other systems with the GNSS clock of the MX50 system (PPS and serial interface). Furthermore it provides two independent trigger signals and two independent event signals.

The use of this connector requires some very specific and technical knowledge. Please contact Support for more details.

System Socket: LEMO EEG.2K.314.CLL

Possible connector: LEMO FGG.2K.314.CLAC85

Pin No.	Name	Type	Comment
1	Trigger 1	5 V TTL	Output positive edge logic (default)
2	GND		Ground for Trigger 1
3	Event 3	High Level: > 4.0 V DC Low Level: < .8 V DC	Opto-isolated Input
4	GNDI		Ground for Opto-isolated Event 3
5	Trigger 2	5 V TTL	Output negative edge logic (default)
6	GND		Ground for Trigger 2
7	Event 4	High Level: > 4.0 V DC Low Level: < .8 V DC	Opto-isolated Input
8	GNDI		Ground for Opto-isolated Event 4
9	Com 4 RX	RS232	RS232 Receiving Channel
10	Com 4 TX	RS232	RS232 Transmitting Channel
11	GND		Ground for Com 4
12	PPS 1	5 V TTL	Output positive edge logic
13	PPS 2	5 V TTL inverted	Output negative edge logic
14	GND		Ground for PPS 1/2

---

 **WARNING** - For each signal, the dedicated ground terminal (GND) must be used.

---

## Detailed Signal Description

- **Trigger 1/2:**

Provides the distance based Trigger signal configured in the TMI software.

- **Event 3/4:**

- The MX50 system is capable of simultaneously marking time tag events through the External-Signal connector. These tags may be used to identify the start and/or end of data collection and to synchronize the MX50 data with data from other sensors or systems.

Events are tagged with GPS, UTC. To tag an event, a signal of (High Level: > 4.0 V DC and max. 5.5 V DC; Low Level: > 0.0 V DC and < 0.8 V DC) is input into the MX50 system.

Event time tagging occurs when the MX50 system detects a rising edge (default configuration) on an event line. The time of the edge (accurate to within one microsecond) is captured. The event time is logged for use in postprocessing.

- Guard Time: 20 ms (corresponds to max 50 Hz).

- **Com 4 (RX/TX/GND):**

- Port settings:

Setting	Value
Interface	RS-232
Baud Rate	2400 to 115200 (9600)
Parity	None
Data Bits	8
Stop Bits	1
Flow Control	None

- NMEA Messages and Data Format:

The MX50 system outputs data on the COM4 port using the NMEA standard 0183 format. The supported NMEA message formats are listed below. The MX50 system has several different sentence formats available for output to third-party equipment. Any or all of the sentences are available for output.

Update Rate: 1 ... max. 50 Hz

TalkerID: GP

Message	Output
GST	Pseudo-range measurement noise statistics
GGA	Position
HDT	Heading
ZDA	Time and date
VTG	Track and speed
PASHR	Attitude
GGA2	Position data, with GNSS fix, geoidal separation
PPS	PPS, UTC time, PPS time recovery
\$EVT3	Timed event #3*
\$EVT4	Timed event #4*
GGK	GNSS fix
RMC	NMEA Recommended Minimum Specific Navigation Data

Not an NMEA 0183 message but it is compatible with the standard.

**NOTE** – All real-time position and orientation message strings are expressed with respect to the Reference Body Frame.

- PPS 1/2:

- The MX50 system uses the one Pulse Per Second (PPS) signal from a GNSS receiver for internal timing requirements. A duplication of this signal is provided on the connector to allow external equipment to be synchronized with the MX50 system.





The PPS output port is an active circuit. Ensure that NO 'input signal' is connected to the PPS output port, otherwise damage may result.

- The PPS signal is a TTL level strobe (pulse width 1 ms) that occurs at a 1 Hz rate. The rising/falling edge (PPS 1 / PPS 2) of the strobe is coincident with the exact GPS second. The corresponding time message that specifies the UTC time of the PPS is available in multiple formats on the COM4 port.

## Setting the Location of the GAMS Antenna

**Why Use a GAMS?** The GAMS helps to speed up the initialization of the navigation system inside the MX50 system. The initialization procedure is a mission-specific task, which has to be done before every mission.

Using a GAMS, not only is the initialization time reduced but also no special driving maneuvers are necessary to complete initialization.

**GAMS Setting Requirements.** Before using a GAMS, you need to specify the three XYZ components (XYZ offsets) of the vector connecting the GAMS antenna to the External Reference Point on the Roof Rack. And remember these measurements need to be done every time you re-install the GAMS on the car roof for a new mission. Depending on how you want to use the GAMS, specific requirements need to be met when setting up the GAMS:

- **If you intend to use a GAMS just for collecting data:**
  - XYZ offsets should be measured with an accuracy of only 10 cm (or better).
  - Base length between primary and secondary antennas of 2 m is recommended (min. not less than 1.6 m).
- **If you intend to use a GAMS for later being able to postprocess the collected navigation data,** tighter requirements need to be met:
  - XYZ offsets should be measured with an accuracy in the order of a few millimeters.
  - Base length between primary and secondary antennas should not be less than 2.0 m.
  - The primary and secondary antennas used **MUST** be of the same type. **DO NOT** mix different antenna types in the setup.
  - **IMPORTANT-** Offsets should always be measured with respect to the L1 antenna phase center (APC) of the corresponding antenna!

**What to Measure exactly?** The GAMS antenna being usually installed close to the front of the Roof Rack (on the roof of the car), it's easier to measure the offsets from the GAMS antenna to the top-left front corner of the Roof Rack (these are relatively short distances) rather than measuring those to the external reference point (these distances, which are larger, would be more difficult to measure). Because the components of the distance from the top-left front corner of the Roof Rack to the External Reference point are accurately known, it will be easy to deduce all the offset values separating the GAMS antenna from the External Reference Point.

**GAMS Setup Instructions** (see also illustration below):

- Measure the XYZ offsets between the GAMS antenna and the top-left front corner of the Roof Rack (this corner is shown in green below).
- Add your measured offset values (in blue) to the known offsets (in yellow). The resulting values describe the position of the GAMS antenna with respect to the External Reference Point on the Roof Rack.
- Enter these values as *Lever Arm X*, *Lever Arm Y*, *Lever Arm Z* in the TMI software when setting the GAMS before you make it active.

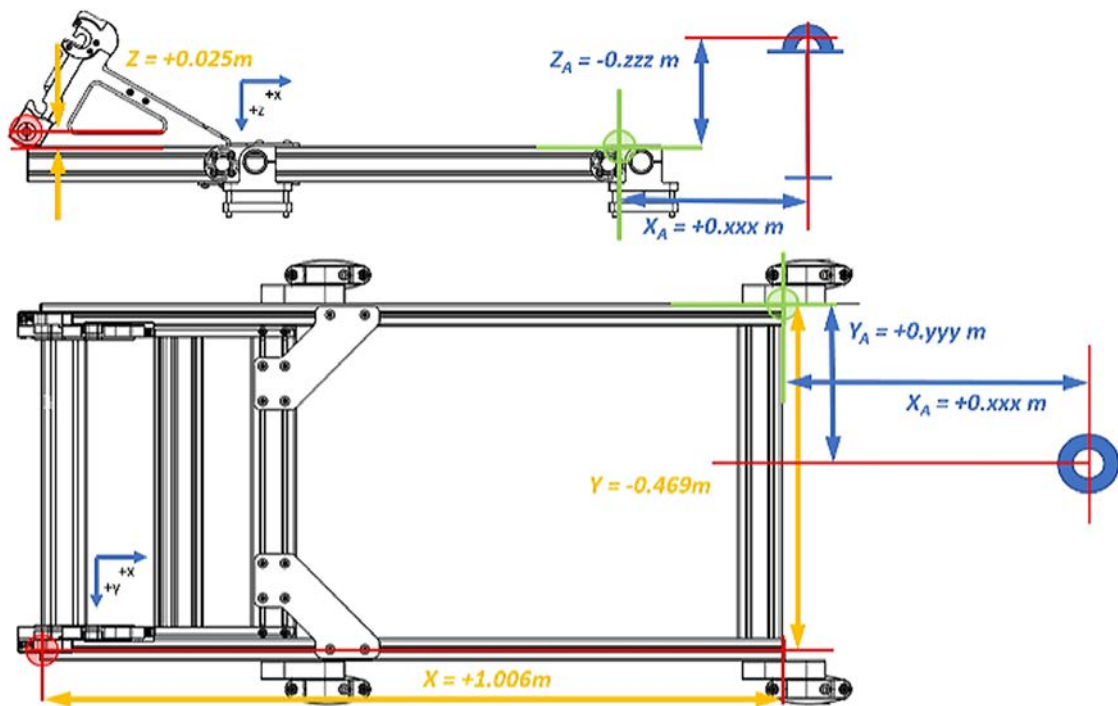

● Location of External Reference Point on Trimble standard Roof Rack.

● Location of top-left front corner of the Trimble standard Roof Rack. Its offset values along the lever arms compared to the location of the External Reference Point are fixed and known. These are given in the right-hand column:

X= +1.006 m  
 Y= -0.469 m  
 Z= +0.025 m



Location of GAMS antenna. Its offset values along the lever arms compared to the location of the Ext. Ref. Point are calculated as follows:

Lever Arm X= +1.006 m + 0.xxx m
Lever Arm Y= -0.469 m + 0.yyy m
Lever Arm Z= +0.025 m - 0.zzz m

---

Where 0.xxx, 0.yyy and 0.zzz are your measured values (in meters).

